



Safety by Design

OPERATION MANUAL



**Radiator Coolant
Service Center**



*Revision: 1.1
11/2009*

Table of Contents

Introduction.....2

Safety Precautions.....3

System Functional Components.....4

Before Starting.....4-5

Control Panel Descriptions and Functions.....7

Pressure Relief Procedure.....7

Drain and Fill versus Reverse Flush.....8

DRAIN AND FILL EXCHANGE

Draining Cooling System.....9

Vacuum Leak Testing and Filling Cooling System10

Topping off Cooling System10

REVERSE FLUSH

Connection Possibilities11

1) Traditional Flow.....11

2) Reverse Flow.....11

3) Thermostat.....11-12

4) Coolant Reservoir, Pressure Cap.....12

REVERSE FLUSH PROCEDURE – Traditional Flow Cooling System

1) Lower Coolant Level.....12

2) Adapter Set-Up.....13

3) Pressure Test.....13

4) Exchange.....13

5) Disconnecting.....14

6) Topping Off.....14

Changeover of PRIMARY (internal) Coolant Tank to ALTERNATE (external) Coolant Tank15

Changeover of ALTERNATE (external) Coolant Tank to PRIMARY (internal) Coolant Tank16

Empty Used Coolant17

Empty Used Coolant – using HOLD feature17-18

Empty Tool Reservoir18

Troubleshooting19

Statement / Commitment.....20

Introduction

Thank you for purchasing Symtech Corporation’s **VFX 1** Radiator Coolant Service System. The **VFX 1** is a very simple yet effective machine design to quickly perform all required periodic maintenance services for automotive cooling systems. It is extremely easy to operate, environmentally safe, and designed for the greatest speed and efficiency.

The Operations Manual **MUST** be read and **COMPLETELY UNDERSTOOD** in order to properly operate the unit and experience the highest return on investment. Refer to the manual in the future for continued safe operation. If you encounter difficulties in the operation, understanding of procedures, or have general service questions, please do not hesitate to call us at **888-884-8182**.

Please record the purchase date, serial number and distributor purchased from below for future reference and assistance in technical issues.

Purchase Date: _____

Serial Number: V1- _____
Located on Back of Unit

Purchased From: _____

TECHNICAL SUPPORT

1-888-884-8182
Central Standard Time
8AM to 5PM, Monday through Friday



Safety by Design

SAFETY PRECAUTIONS

WARNING: FAILURE TO FOLLOW PRECAUTIONS CAN RESULT IN INJURY OR DEATH

- **Always use extreme caution and forethought when servicing automotive systems! Automotive systems are extremely hot and contain high pressure.**
- Always read and understand the entire Operations Manual before operating!
- Always wear proper eye and skin protection when operating equipment!
- Always keep fire extinguisher nearby for flammable conditions!
- Always keep hair, loose clothing, hoses, etc. securely away from moving parts!
- Always keep work area well ventilated to prevent carbon monoxide build up!
- Always comply with local, state, and federal regulations concerning fluid disposal!
- Always clean up and report spill in a proper manner!
- Always read and understand the **Material Safety Data Sheets (MSDS)** for particular fluids!
- Always seek emergency medical attention for ingestion of, or eye contact with fluid!
- Always replace radiator cap after performing “Lower Coolant Level” function!
- Do not use harsh cleaners such as thinners or petroleum based solvents to clean the unit and or unit components. Certain harsh chemicals can negatively affect the durability and appearance – only use mild cleaners.
- Periodically, inspect the hoses and cone of the VFX 1 for normal wear or damage. Contact Symtech for replacement components.
- **WARNING: Cooling systems can be under extreme pressure – extra care must be taken to properly protect against accidental releases of hot, pressurized coolant.**
- **WARNING: Do not modify or alter the unit in any manner whatsoever. Modification of the unit to perform unspecified actions can endanger personnel and or damage the vehicle and unit!**
- **WARNING: Never point the cone at self or other personnel while operating the unit!**
- **WARNING: HOSE CONNECTIONS AND FITTINGS CAN BECOME EXTREMELY HOT DURING COOLANT FLUSH AND VACUUM DRAIN AND FILL OPERATIONS, CAUTION MUST BE TAKEN WHEN HANDLING FITTINGS!! WEAR GLOVES OR USE OTHER MEANS TO SHIELD AGAINST INJURY!!**
- **WARNING: TAKE NECESSARY PRECAUTIONS TO SECURE THE VEHICLE WHEN PERFORMING COOLANT SERVICES!!**

VFX 1 System Functional Components

FRONT:

1. CONTROL PANEL
 - 1A. AIR CONTROL VALVE
 - 1B. FUNCTION CONTROL VALVE
 - 1C. FLUID CONTROL VALVE
2. PRESSURE GAUGE
3. NEW FLUID FILL CAP
4. NEW FLUID TANK SELECTOR
5. NEW AND USED FLUID HOSES
6. NEW FLUID ALTERNATE TANK CONNECTION
7. NEW FLUID ALTERNATE TANK
8. EXTRACTION PORT, TOOL STORAGE COMPARTMENT DRAIN RESERVOIR.
9. RED/ NEW COOLANT FLOW CONTROL VALVE
10. BLACK/USED COOLANT FLOW CONTROL VALVE
11. TOOL STORAGE COMPARTMENT



REAR:

1. NEW FLUID TANK SIGHT GAUGE
2. USED FLUID TANK SIGHT GAUGE
3. SHOP AIR CONNECTION
4. INLINE FILTER
5. SERIAL NUMBER PLATE
6. 5 GALLON *PRIMARY* (INTERNAL) NEW FLUID
7. 15 GALLON USED FLUID TANK

Before Starting

- 1) Upon unpacking the **VFX 1** verify all components as depicted below are included. Contact Symtech if any components are damaged or missing.
 - 2) Thoroughly read manual and become familiar with control panel and components!
 - 3) Prepare appropriate mixture of water and **vehicle specified type** of coolant in the new fluid container. Always use specified coolant per vehicle manufacturer's specification or vehicle owner's manual. The VFX 1 is shipped standard with "1", *PRIMARY* (internal) and "1" ALTERNATE (external) 5-gallon new coolant tanks. Additional tanks can be ordered from Symtech as required.
 - 4) Verify that all valves are in the correct position – see information on control panel valves and verify flow control valves located at hose ends are closed to avoid accidental operation or spills. (*See Pg 5-7*)
 - 5) Connect the VFX 1 to clean shop air supply – minimum constant pressure of 70psi and maximum pressure of 120psi. Shop air must be filtered clean air as debris may impact performance of the unit.
 - 6) The VFX 1 is now ready to perform coolant fluid exchanges.
- ❖ **NOTE: NEVER over fill *PRIMARY* (internal) New Fluid Tank, doing so could cause a small amount of fluid to seep out of the overflow tube, leaving traces of fluid in bottom of VFX 1 case.**
 - ❖ **NOTE: NEVER put anything but coolant and water mix in the new coolant tank of the VFX 1. If A *CHEMICAL* cooling system flush is to be used, it should be added and circulated in the cooling system prior to exchange functions being performed.**
 - ❖ **NOTE: Always test the freeze point of coolant after exchange is complete to verify the coolant offers proper protection for geographic area.**



Control Panel Descriptions and Functions

The following information is intended to familiarize the VFX 1 operator with the control panel and its functions. Time must be taken to read and understand the VFX 1 controls and operation for safe and acceptable performance of the unit. All control panel valve functions are color coded to aid technician in the function selection process. Simply match all three control panel valves to the matching colored function legends at each control panel valve - #1, #2, and #3. Please refer to diagram on next page for full details.

1

AIR CONTROL – Controls supplied shop air pressure flow and is the first step in exchange process.

OFF position stops all air flow – valve should always be returned to the OFF position after completion of each function. Automatic pressure relief of new fluid hose occurs when in the off position.

(PRESSURE) – FLUSH (*BLUE*), TOP OFF (*GREEN*), EMPTY USED (*PURPLE*), – This position directs shop air pressure to the new fluid pump. Allowing user to perform reverse FLUSH, top off, and EMPTY USED fluid tank procedures.

(VACUUM) DRAIN AND FILL (*RED*), LOWER LEVEL (*YELLOW*), – This position directs shop air pressure to vacuum venture where vacuum is created then stored within the onboard tank. . Allowing the user to perform the vacuum DRAIN & FILL, and LOWER LEVEL procedures

2

FUNCTION CONTROL – Controls pressure or vacuum flow to used coolant tank and is the second step of the process.

THIS VALVE SHOULD ALWAYS BE DIRECTED TO FLUSH (*BLUE*) TO SAVE A STEP IN MOST CASES AND TO LEAVE THE USED COOLANT TANK AT ATMOSPHERIC PRESSURE. THE FUNCTION CONTROL VALVE ONLY NEEDS TO BE ADDRESSED WHEN EMPTY USED, TOP-OFF, OR HOLD FUNCTIONS ARE REQUIRED TO BE PERFORMED.

HOLD, TOP OFF (*GREEN*) – This Position stops the vacuum or pressure flow to and from the used fluid tank, allowing the user to perform the “remote” EMPTY USED tank procedure, and to prevent air pressure from reaching used tank during TOP OFF procedure.

FLUSH (*BLUE*), DRAIN AND FILL (*RED*), LOWER LEVEL (*YELLOW*), – This position diverts generated vacuum to the used coolant tank where it is stored, allowing the user to extract used coolant from vehicle during the DRAIN & FILL and LOWER LEVEL procedures. This position also prevents pressure build up in used fluid tank during FLUSH procedure.

EMPTY USED (*PURPLE*) – This position allows internally regulated air pressure to build in used fluid tank to ultimately force used coolant from the used fluid tank.

3

FLUID CONTROL – Controls coolant flow to and from machine and/or vehicle depending upon function selected.

OFF/ PRESSURE TEST – This position stops all coolant flow to and from vehicle, isolating vehicle from machine for pressure testing procedure.

NEW- TOP OFF (*GREEN*), FILL (*RED*) – Allows new coolant to flow from selected new fluid tank to vehicle’s coolant system.

USED- FLUSH (*BLUE*), DRAIN (*RED*), LOWER LEVEL (*YELLOW*), EMPTY USED (*PURPLE*), This position Allows used coolant flow to the used coolant storage tank during FLUSH, DRAIN, and LOWER LEVEL procedures. This position also allows user to perform the “remote “or standard EMPTY USED tank procedure

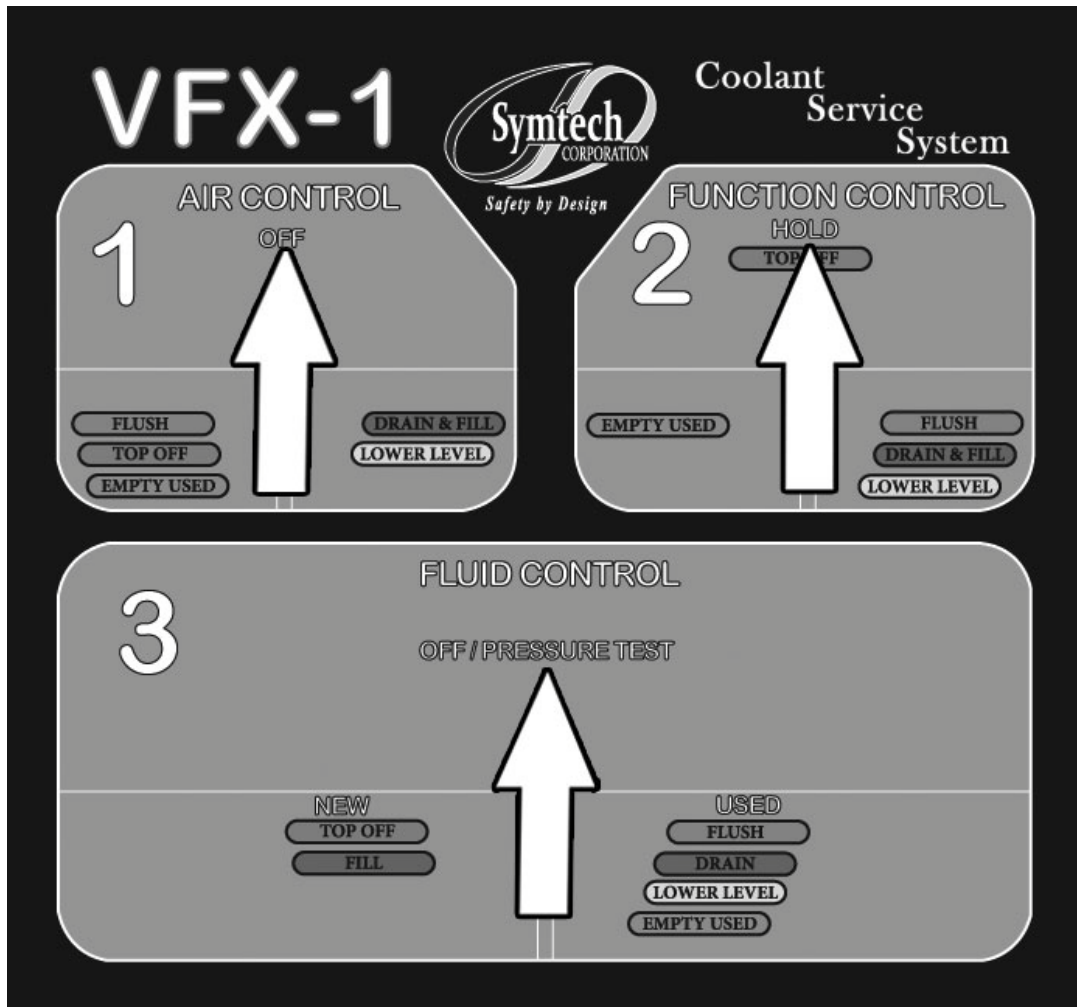

FLOW CONTROL VALVES

The flow control valves at the end of the RED/NEW and BLACK/USED hose ends should always be in the closed position until desired function is ready to be performed. This prevents accidental operation or spills until technician is ready to remove and/or add coolant.

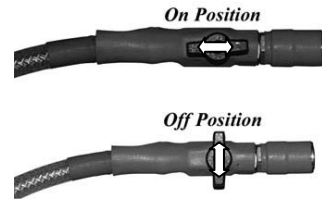

WARNING: HOSE CONNECTIONS AND FITTINGS CAN BECOME EXTREMELY HOT DURING COOLANT FLUSH AND VACUUM DRAIN AND FILL OPERATIONS, CAUTION MUST BE TAKEN WHEN HANDLING FITTINGS!! WEAR GLOVES OR USE OTHER MEANS TO SHIELD AGAINST INJURY!!

CONTROL VALVE, PRIMARY (INTERNAL) / ALTERNATE (EXTERNAL) NEW FLUID COOLANT TANK(S)

Coolant Tank Control Valve, switches between the *PRIMARY* (internal) coolant tank and an *ALTERNATE* (external) coolant tank, the *OFF* position is used only when servicing the *PRIMARY* (internal) coolant filter.



Pressure Relief Procedure

The Pressure Relief procedure is designed to allow immediate servicing of “HOT VEHICLES” by alleviating cooling system pressure versus waiting for vehicle to cool down. **EXTREME CARE must still be taken as hot coolant can cause injury.**

- 1) Verify adequate capacity for used fluid in used fluid sight gauge. Refer to EMPTY USED coolant section to empty used coolant tank.
- 2) Properly secure vehicle against accidental movement.
- 3) Verify all VFX 1 Control panel valves are in the neutral position, AIR CONTROL Valve #1, OFF, FUNCTION CONTROL Valve #2, HOLD, and FLUID CONTROL Valve #3, OFF. (Fig 1)
- 4) Connect clean shop air supply (70-120psi).
- 5) Turn AIR CONTROL valve (#1) FUNCTION CONTROL valve (#2) and FLUID CONTROL valve to the right, LOWER LEVEL (YELLOW). (Fig 2) Vacuum will begin to build on the compound gauge.
- 6) Insert rubber “pressure relief hose” into opening of cone. (Fig 3) Connect cone assembly to BLACK/USED coolant hose and open used flow control valve.
- 7) Remove cooling system overflow tube or hose from radiator neck or Remote Reservoir tank, (Fig 4). Securely connect rubber hose extension to overflow tube. Note: The rubber hose extension can be omitted and the cone opening can be placed directly on large overflow tubes.
- 8) Slowly open radiator or Remote Reservoir cap observing vacuum level. Upon “cracking” seal, used coolant will be extracted through overflow tube creating a low pressure area behind the system’s cap.
- 9) When no used coolant is observed flowing through the clear hose and a vacuum of at least 15” is reached, the radiator or Remote Reservoir cap can be safely removed.
- 10) Once cap is removed return all control panel valves to neutral position and flow control valves at hose ends OFF. (Fig 5)

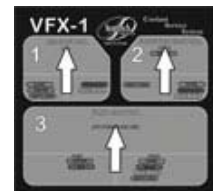

Figure 1

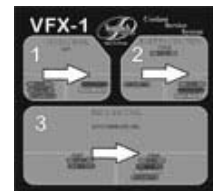

Figure 2



Figure 3

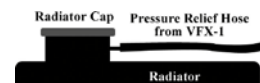

Figure 4

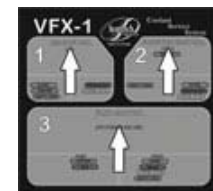

Figure 5



DRAIN and FILL (RED) versus REVERSE FLUSH (BLUE)

The VFX 1 Coolant exchange system offers two methods to easily perform coolant exchanges: DRAIN AND FILL (*RED*) and REVERSE FLUSH (*BLUE*). The following information describes the basic differences between the two types, and the advantages and disadvantages of each.

DRAIN AND FILL (RED) - entails using shop air pressure to create vacuum in the VFX 1. This vacuum is then used to pull used coolant from the vehicle's cooling system via the radiator cap or Remote Reservoir tank opening. The resultant vacuum created in the vehicle's cooling jacket is in turn used to pull in new coolant.

ADVANTAGES of the DRAIN AND FILL (*RED*) exchange are; speed, simplicity, and ease of use as the cooling system is easily accessed. Shop mess is minimized as the coolant system remains intact and air pockets are eliminated from the cooling system by the vacuum level reached during extraction. DRAIN AND FILL does not involve adapters or in-depth knowledge of cooling systems.

DISADVANTAGES of a DRAIN AND FILL (*RED*) coolant exchange is less efficient on some vehicles. Some coolant system configurations do not allow a large percentage of used coolant to be evacuated via vacuum and the exchange process may produce inferior results. Many times the DRAIN AND FILL procedure can be repeated to obtain acceptable results, but this may be inefficient and more costly than reverse flushing.

REVERSE FLUSH (BLUE) – utilizes pressurized new coolant entering the vehicle's cooling system, usually through the upper radiator connection, flushing backwards through the engine block, and up through the radiator forcing the used coolant out into the unit's used coolant tank. Some systems have reverse flow cooling systems and the new coolant may flush through the radiator first, then the engine block and out.

ADVANTAGES; The REVERSE FLUSH (*BLUE*) coolant exchange process is the most efficient and effective method as the backwards flow of new coolant purges the old coolant and most debris out of the system. Less new coolant is used to achieve excellent results.

DISADVANTAGES; A REVERSE FLUSH (*BLUE*) exchange requires breaking into the cooling system via adapters and hoses. This sometimes requires more time to perform exchange, creates air pockets that will need to be "burped" from the vehicle, and there is more potential for spillage of coolant than a DRAIN AND FILL service. The REVERSE FLUSH exchange also requires a more in depth understanding of cooling system flow and operation.

Both types of exchanges are easily performed by simply following the colored control panel valve sequence.

DRAIN AND FILL EXCHANGE (RED)

NOTE: The RED/NEW coolant hose is not used to perform a DRAIN AND FILL (RED) coolant exchange.

Draining Cooling System

- 1) Verify **Pressure Relief Procedure** described above has been performed.
- 2) Verify adequate capacity for used fluid with used fluid sight gauge. Refer to **EMPTY USED** coolant section to empty used coolant tank.
- 3) Turn **AIR CONTROL** valve (#1) **FUNCTION CONTROL** valve (#2) and **FLUID CONTROL** valve (#3) to the right, **LOWER LEVEL (RED)**. Vacuum will begin to build on the compound gauge. (Fig 2)
- 4) Insert longest nylon tube extension into small cone opening. Connect cone assembly to **BLACK/USED** coolant hose. (Fig 2)
- 5) Insert extension tube into overflow tank. The extension tube should reach the bottom of the overflow tank. **Do not allow cone to seat on plastic overflow tanks.**
- 6) Open **BLACK/USED** coolant flow control valve. Used coolant will be removed. Completely empty the overflow tank.
- 7) Close **BLACK/USED** coolant flow control valve. Remove nylon tube extension from cone.
- 8) Insert cone tip into radiator neck or coolant reservoir tank opening and open **BLACK/USED** coolant flow control valve. The vacuum will securely seat and seal the cone into the opening and used coolant will begin to be extracted from the cooling system. (Fig 3)

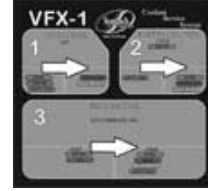

Figure 1

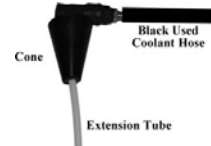

Figure 2

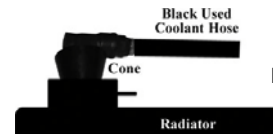

Figure 3

Note: For better exchanges, insert the longest possible nylon tube extension into the radiator or coolant reservoir tank, being extremely careful not to force the tube or damage the internals of the radiator or coolant reservoir tank. Once the longest possible nylon tube extension has been determined insert the extension securely into the cone. This “longer dip-tube assembly” will allow more of the used coolant to be removed from the system versus no dip-tube assembly.

Note: Some radiator neck openings are shallow – internal components such as the core or supports are in close proximity to the opening. The neck may be so shallow that the cone will bottom out on the core or internal supports preventing the cone to seal on the radiator neck. Trimming or cutting back the narrow end of the cone to the required diameter may be necessary to acquire a leak proof seal.

- 9) Once cone is securely seated, start vehicle and observe used coolant hose and vacuum gauge. When fluid stops flowing and the vacuum gauge has reached at least 20in vacuum, turn off vehicle!
WARNING; be careful not to overheat the vehicle by running the vehicle too long!!
WARNING; Fittings can become extremely hot during DRAIN / FILL exchange.
- 10) **Do not remove cone from system!!** Vacuum reached in cooling system is used to “pull in” new coolant. If cone is removed, or seal is lost, the vacuum must be restored to remove air from system and allow new coolant to be pulled into the vehicles cooling system.
- 11) Return **AIR CONTROL** valve #1 and **FLUID CONTROL** valve #3 to **OFF** position. Turn **FUNCTION CONTROL** valve #2 to **HOLD** position. (Fig 4)

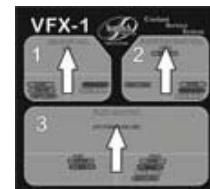

Figure 4

Vacuum Leak Testing Cooling System (This test can only be performed on cool engines)

While the cooling system is in a “trapped vacuum condition” from the **Draining Cooling System** procedure above, the vacuum level can be recorded and checked over a period of time, usually two minutes. If the vacuum level decreases, there may be a leak in the cooling system. Although pressure testing is the preferred leak test method, this quick test will indicate large leaks requiring immediate attention before introducing new coolant into a leaking system.

Filling Cooling System

- 1) Upon completion of “Draining” procedures, the cooling system can be refilled. The vehicle’s engine continues to run during this procedure.
- 2) Verify the system still maintains at least 20inHg vacuum after “Draining” steps. If the system vacuum is inadequate, drain system steps will need to be repeated to re-establish required vacuum level to pull-in new coolant. Refer to “Draining Cooling System”
- 3) Verify adequate amount of new coolant in new coolant tank to perform refill.
- 4) Turn FLUID CONTROL valve (#3) to the left, FILL (*RED*). New coolant will flow into vehicle’s cooling system until vacuum equalizes. Completion of this step is signified when new coolant flow ceases and vacuum gauge reaches “-3 ~ -5 inHg”. (*Fig 5*)
- 5) Return all control panel valves to neutral position, (*Fig 6*) and BLACK/USED coolant flow control valve at hose end OFF.

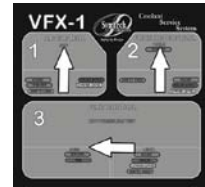

Figure 5

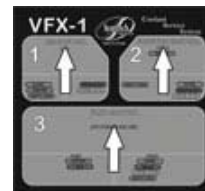

Figure 6

Topping Off Cooling System

- 1) Verify all control panel valves are in neutral position. (*Fig 1*) Turn both flow control valves at hose end OFF.
- 2) Turn AIR CONTROL valve (#1) and FLUID CONTROL Valve (#3) to the left, TOP OFF (*GREEN*), FUNCTION CONTROL valve (#2) straight up, TOP OFF (*GREEN*). (*Fig 2*)
- 3) Connect cone assembly to RED/NEW coolant flow control valve. (*Fig 3*)
- 4) Place vacuum cone into radiator or Remote Reservoir neck. Slowly open RED/NEW coolant flow control valve, observing coolant fluid level. (*Fig 3*)
- 5) Close RED/NEW coolant flow control valve when proper coolant level is reached.
- 6) Fill overflow tank to proper level following the procedures described in steps 4 and 5.
- 7) Return all control panel valves to neutral position. (*Fig 4*)
- 8) Replace radiator / remote reservoir, and overflow caps.

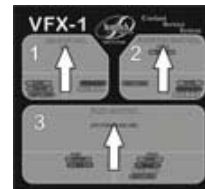

Figure 1

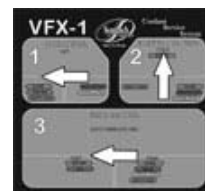

Figure 2

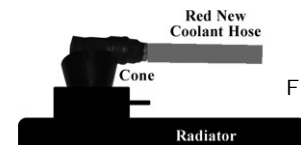

Figure 3

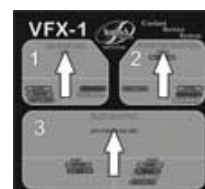

Figure 4

REVERSE FLUSH EXCHANGE (BLUE)

NOTE: Before Starting, Control Panel Descriptions and Functions must be read and understood. If vehicle is hot, Pressure Relief procedures must be performed before attempting a Reverse Flush exchange!! The vehicle remains OFF during the entire Reverse Flush

Connection Possibilities

Reverse Flush exchanges entail opening the cooling system up at either end of the upper radiator hose connection via step adapters and adapter hoses of the appropriate size, connect the VFX 1 new and used coolant lines to the installed adapters and flush the used coolant out via new coolant being introduced. There are three possible connection scenarios to achieve the proper flow direction to successfully perform the exchange and each scenario must be tried in the following order:

1. **TRADITIONAL FLOW** - Most vehicles have traditional coolant flow – coolant flows downward through the radiator, pulled by the water pump through the lower radiator hose, pushed through the engine block water jacket, upward through the heads and intake, out the thermostat (if engine is to normal operating temperature) and back to the radiator to repeat the process via upper radiator hose. Please refer to diagram.

To Reverse Flush this type system, the upper radiator hose is disconnected, and new coolant is introduced via adapters and adapter hoses against the “backside” of the thermostat. The pressure of the new coolant forces open the thermostat and flows backwards from normal flow “pushing” the used coolant and debris through the cooling system and out the upper radiator hose into the used fluid tank of the VFX 1.

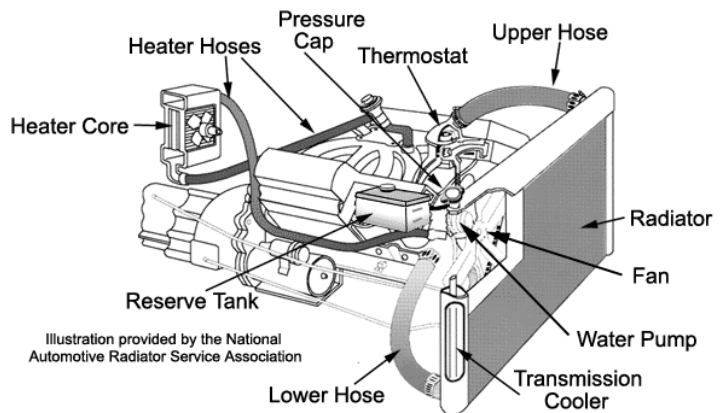

NOTE: After connecting unit for Traditional Flow, if new coolant pump DOES NOT pulsate and used coolant IS NOT flowing from radiator to unit, **RECHECK all connections, control panel valves, and flow control valves for correctness and RETRY.** IF problem persists, the vehicle’s cooling system is a **REVERSE FLOW SYSTEM** or **THE THERMOSTAT WILL NOT OPEN FROM THE BACK SIDE.**

2. **REVERSE FLOW** – Reverse Flow cooling systems circulate in the opposite direction of traditional systems, because the thermostat is located in the bottom of the engine block. This means coolant flows up through the radiator, through the upper radiator hose connection, into the top of the engine block, downward through the engine block, through the thermostat (if the engine is at operating temperature), and back to the lower radiator via lower radiator hose for re-circulation.

To Reverse Flush these vehicles follow the same procedures as a Traditional Flow flush, LOWER LEVEL, ADAPTER SET-UP, **However reverse the connection of the coolant flow control valves. Connect the RED/NEW coolant flow control valve to the upper radiator hose adapter and the BLACK/USED coolant flow control valve connected to the engine block outlet adapter.**

PRESSURE TEST, DISCONNECTING, and TOPPING OFF procedures remain the same once the fluid exchange is complete.

IF Reverse Flow connection is attempted and new coolant pump STILL DOES NOT pulsate and used coolant IS NOT flowing from engine block to unit, RECHECK all connections, control panel valves, and flow control valves for correctness and RETRY. IF problem persists, refer to third connection procedure below.

3. **THERMOSTAT** – The third connection option is utilized only when **TRADITIONAL** and **REVERSE** methods do not work. The third option does not allow for a reverse flush, but does allow a coolant fluid exchange. Follow the same procedures as a Traditional Flow flush, LOWER LEVEL, ADAPTER SET-UP, **however reverse the**

connection of the coolant flow control valves as described in Reverse Flow (#2), with the RED/NEW coolant flow control valve connected to the upper radiator hose adapter and the BLACK/USED flow control valve connected to the engine block outlet adapter.

The vehicle is started and allowed to reach normal operating temperature which allows the thermostat to open allowing coolant to flow from the unit through the cooling system and back into the unit. The coolant is flowing as normal when operating temperature is reached, but the unit is in the loop receiving used coolant as it is pumped out and injecting new coolant in its place.

The flow may stop and start intermittently, as the new coolant cools the thermostat, closing the thermostat until normal operating temperature is reached, re-opening the thermostat and flow resuming.

PRESSURE TEST, DISCONNECTING, and TOPPING OFF procedures remain the same once the fluid exchange is complete.

4. **RESERVOIR TANK, PRESSURE CAP:** Systems that do not have a pressure cap on the radiator will in most cases have a pressure cap on a Remote Reservoir Tank. In those instances it will be necessary to pinch closed the hoses to the reservoir tank during the coolant exchange.

If hoses are not pinched closed, it is possible for coolant to be forced out of pressure cap and also the coolant exchange will not be an entire system flush as coolant is routed around the engine and through the reservoir.

COMPLETE THE FOLLOWING STEPS TO REVERSE FLUSH A TRADITIONAL FLOW COOLING SYSTEM:

LOWER LEVEL

The LOWER LEVEL (*YELLOW*) procedure is intended to reduce coolant spillage created when disconnecting the upper radiator connection by lowering the coolant level below the disconnection point.

- 1) Verify adequate amount and type of new coolant to complete exchange is in new coolant tank.
- 2) Verify adequate capacity for used fluid in used fluid sight gauge. Refer to EMPTY USED coolant section to empty used coolant tank.
- 3) Verify that all VFX 1 Control panel valves are in the neutral position, (*Fig 1*) and flow control valves at hose ends are off.
- 4) Connect clean shop air supply (70-120psi).
- 5) Turn AIR CONTROL valve (#1) FUNCTION CONTROL, valve (#2) FLUID CONTROL Valve and valve (#3) to the right LOWER LEVEL (*YELLOW*), (*Fig 2*). Vacuum will begin to build on the compound gauge.
- 6) Connect vacuum cone with extension tube to BLACK/USED coolant hose and open BLACK/USED coolant flow control valve at hose end. (*Fig 3*)
- 7) Insert vacuum cone with extension tube into overflow tank and remove all used coolant from tank. **Do not seat cone into overflow tanks opening.**
- 8) Remove radiator cap – **Has Pressure Relief Procedure been performed?** - insert vacuum cone with extension tube being careful not to damage radiator components.
- 9) Lower coolant level as far as possible by observing used coolant flow in hose.
- 10) When used coolant flow ceases, close used coolant flow control valve at hose end.
- 11) Return all control panel valves to correct neutral position, (*Fig 4*) and flow control valves at hose ends off.
- 12) **REPLACE RADIATOR CAP.**

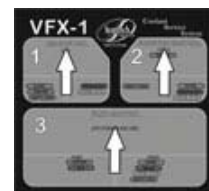

Figure 1

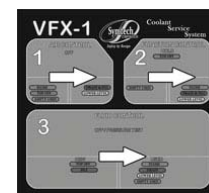

Figure 2

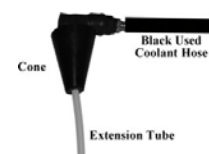

Figure 3

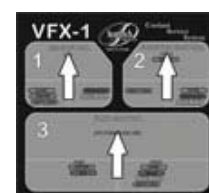
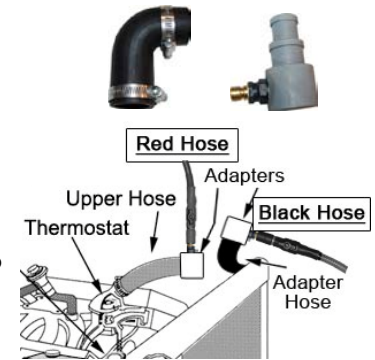

Figure 4

ADAPTER SET-UP

- 1) Disconnect the upper radiator hose at most accessible point.
- 2) The appropriate size adapter hose along with its matching step adapter is installed on the exposed outlet neck and secured with correct hose clamps.
- 3) The tightest fitting step adapter is next installed and secured by hose clamps to the vehicle's exposed radiator hose making sure the connection plugs are accessible.
- 4) Connect the RED/NEW coolant flow control valve to the step adapter leading to the thermostat or engine block.
- 5) Connect the BLACK/USED coolant flow control valve to the step adapter leading to radiator.



PRESSURE TEST

A cooling system pressure test to detect leaks in the cooling system can be performed using the VFX 1. Care must be taken not to over pressurize the system during this test and the radiator cap must be in proper working order to act as a safety outlet for excessive pressure.

- 1) Turn AIR CONTROL valve (#1) Left, FUNCTION CONTROL valve (#2) Right, and FLUID CONTROL valve (#3) OFF / PRESSURE TEST. (Fig 1)
- 2) Open BLACK/USED coolant flow control valve and VERY SLOWLY, open RED/NEW coolant flow control valve at hose end, observing increasing pressure on compound gauge.
- 3) When desired system pressure is obtained (usually 1-2lb below specified system pressure), turn RED/NEW coolant flow control valve at hose end off.
- 4) Observe pressure gauge for two minutes – pressure should not drop.
- 5) If pressure drops, investigate for leaks, resolve, and retest.
- 6) If no pressure loss is observed, return all control panel valves to neutral position, (Fig 3) and flow control valves at hose ends to off.

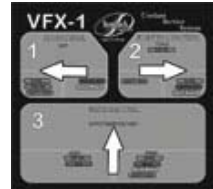

Figure 1



Figure 2

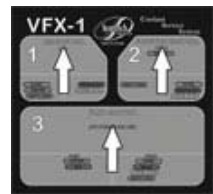

Figure 3

EXCHANGE (BLUE)

- 1) Verify all VFX 1 Control panel valves are in the neutral position, (Fig 1) and flow control valves at hose ends are off.
- 2) Turn AIR CONTROL valve (#1) to the left, FLUSH (BLUE) and FUNCTION CONTROL valve (#2) and FLUID CONTROL valve (#3) to the right, FLUSH (BLUE). (Fig 2) Pressure will begin to build on the compound gauge.
- 3) Open both RED/NEW and BLACK/USED coolant flow control valves.
- 4) The new coolant pump will pulsate and new coolant should be flowing into engine block and used coolant should be flowing from radiator to unit.

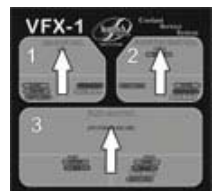

Figure 1



Figure 2

NOTE: IF new coolant pump DOES NOT pulsate and used coolant IS NOT flowing from radiator to unit, RECHECK all connections, control panel valves, and flow control valves for correctness and RETRY. IF new coolant pump STILL DOES NOT pulsate, the vehicle's cooling system is a REVERSE FLOW system or the thermostat will not open from the back side. Close both RED/NEW and BLACK/USED coolant flow control valves and refer to REVERSE FLOW section on page 11.

- 5) Let flushing action continue until used coolant hose matches color of new coolant hose or predetermined amount of new coolant is utilized.
- 6) Return AIR CONTROL valve (#1) to neutral position. (Fig 3)
- 7) Allow 5 to 10 seconds for pressure to drop, then turn both RED/NEW and BLACK/USED coolant flow control valves at hose ends off.

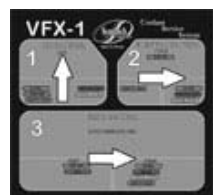

Figure 3

DISCONNECTING (YELLOW)

To minimize spillage from disconnecting the unit from the vehicle the coolant level needs to be lowered again using the LOWER LEVEL (YELLOW) procedures:

- 1) Verify adequate capacity for used fluid in used fluid sight gauge. Refer to EMPTY USED coolant section to empty used coolant tank.
- 2) Verify that all VFX 1 Control panel valves are in the neutral position, (Fig 1) and flow control valves at hose ends are off.
- 3) Turn AIR CONTROL valve (#1), FUNCTION CONTROL valve (#2) and FLUID CONTROL valve (#3) to the right, LOWER LEVEL (YELLOW). Vacuum will begin to build on the compound gauge. (Fig 2)
- 4) Connect vacuum cone with extension tube to BLACK/USED coolant hose and open BLACK/USED coolant flow control valve at hose end.
- 5) Lower coolant level below radiator hose disconnection level. When vacuum reaches 10inHg, coolant level should be below disconnect level. (Fig 3)
- 6) Close BLACK/USED coolant flow control valve at hose end.
- 7) Return all control panel valves to neutral position, (Fig 4) and flow control valves at hose ends to off.
- 8) Step adapters and hose adapters can now be removed and system restored to original configuration.

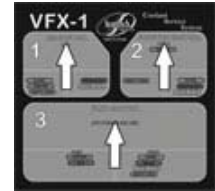

Figure 1

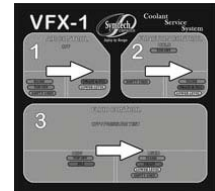

Figure 2



Figure 3



Figure 4

TOPPING OFF

- 1) Verify all control panel valves are in neutral position. (Fig 1) Turn both flow control valves at hose end OFF.
- 2) Turn AIR CONTROL valve (#1) and FLUID CONTROL Valve (#3) to the left, TOP OFF (GREEN), FUNCTION CONTROL valve (#2) straight up, TOP OFF (GREEN). (Fig 2)
- 3) Connect cone assembly to RED/NEW coolant flow control valve. (Fig 3)
- 4) Place vacuum cone into radiator or Remote Reservoir neck. Slowly open RED/NEW coolant flow control valve, observing coolant fluid level. (Fig 3)
- 5) Close RED/NEW coolant flow control valve when proper coolant level is reached.
- 6) Fill overflow tank to proper level following the procedures described in steps 4 and 5.
- 7) Return all control panel valves to neutral position. (Fig 4)
- 8) Replace radiator / remote reservoir, and overflow caps.

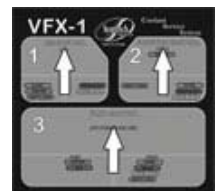

Figure 1

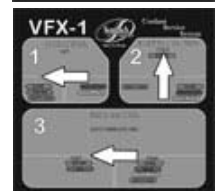

Figure 2

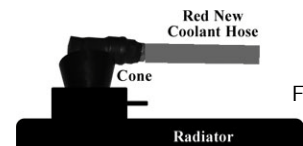

Figure 3



Figure 4

Changeover of PRIMARY (internal) Coolant Tank to ALTERNATE (external) Coolant Tank

The VFX 1 can be used with multiple coolant types by simply switching between the *PRIMARY* (internal) Fluid Tank and an *ALTERNATE* (external) Fluid Tank. The VFX 1 comes with one additional *ALTERNATE* (external) Fluid Tank. Additional tanks can be purchased through Symtech Corporation or one of its Distributors. Inquire for a Distributor location nearest you.

- 1) Verify that all control panel valves are in neutral position, (Fig 1) and flow control valves at hose ends are OFF.
- 2) Connect to clean shop air (70-120psi).
- 3) Move New *ALTERNATE* (external) coolant tank next to VFX 1. Remove Lid from *ALTERNATE* (external) Tank container.
- 4) Pull out the *ALTERNATE* (external) Tank connection hose from VFX 1 and connect coupler to *ALTERNATE* (external) Tank lid. Verify dip-tube is open to atmosphere. (Fig 2)
- 5) Turn Coolant Tank select valve to *ALTERNATE* (external) Coolant Tank.
- 6) Turn AIR CONTROL valve (#1) and FLUID CONTROL valve (#3) to the left, TOP OFF (*GREEN*). (Fig 3)
- 7) Connect cone assembly to RED/NEW coolant flow control valve at hose end.
- 8) Place cone into fill spout of *PRIMARY* (internal) coolant fluid Tank, **SLOWLY** open RED/NEW coolant flow control valve at hose end.
- 9) Close RED/NEW coolant flow control valve at hose end when all coolant has been purged from unit.
- 10) Return all control panel valves to neutral position. (Fig 4)
- 11) Replace lid on *ALTERNATE* (external) coolant tank. Connect *ALTERNATE* (external) tank hose coupling.
- 12) Turn AIR CONTROL valve (#1) and FLUID CONTROL valve (#3) to the left, TOP OFF (*GREEN*). (Fig 5)
- 13) Place cone assembly still connected to RED/NEW coolant flow control valve into tool storage compartment at front of machine, or waist fluid container. **SLOWLY** Open RED/NEW coolant flow control valve at hose end.
- 14) Close RED/NEW coolant flow control valve at hose end when air has been purged from line or a steady stream of coolant from *ALTERNATE* (external) tank flows from unit.
- 15) Return all control panel valves to neutral position. (Fig 6)
- 16) Unit is now ready to perform coolant system service with Exterior Tank coolant.

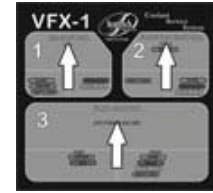

Figure 1



Figure 2

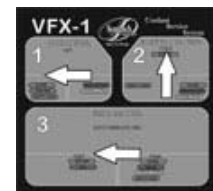

Figure 3

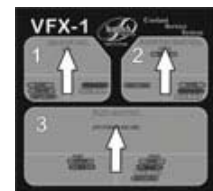

Figure 4

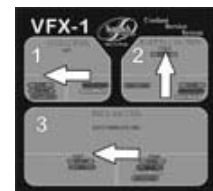

Figure 5

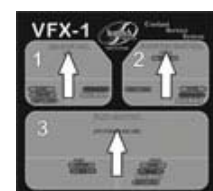

Figure 6

Changeover of ALTERNATE (external) Coolant Tank to PRIMARY (internal) Coolant Tank

- 1) Verify all control panel valves are in neutral position, (*Fig 1*) and flow control valves at hose ends are OFF.
- 2) Connect to clean shop air (70-120psi).
- 3) Remove lid from ALTERNATE (external) coolant tank and connect to ALTERNATE (external) coolant tank hose.
- 4) Turn Coolant select valve to ALTERNATE (external) Coolant Tank.
- 5) Turn AIR CONTROL valve (#1) and FLUID CONTROL valve (#3) to the left, TOP OFF (*GREEN*). (*Fig 2*)
- 6) Connect vacuum cone assembly to RED/NEW coolant flow control valve at hose end.
- 7) Place vacuum cone into ALTERNATE (external) coolant fluid tank, SLOWLY open RED/NEW coolant flow control valve at hose end.
- 8) Close RED/NEW coolant flow control valve at hose end when all coolant has been purged from unit.
- 9) Return all control panel valves to neutral position. (*Fig 3*)
- 10) Replace lid on ALTERNATE (external) Tank and store for future use.
- 11) Turn AIR CONTROL valve (#1) and FLUID CONTROL valve (#3) to the left, TOP OFF (*GREEN*). (*Fig 4*)
- 12) Place cone assembly still connected to RED/NEW coolant flow control valve into tool storage compartment at front of machine, or waist fluid container. **SLOWLY** Open RED/NEW coolant flow control valve at hose end.
- 13) Close RED/NEW coolant flow control valve at hose end when air has been purged from line or a steady stream of coolant from *PRIMARY* (internal) coolant tank flows from unit.
- 14) Return all control panel valves to neutral position. (*Fig 5*)
- 15) Unit is now ready to perform coolant system service with *PRIMARY* (internal) Tank coolant.

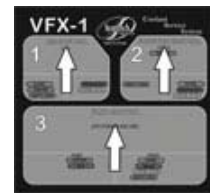

Figure 1

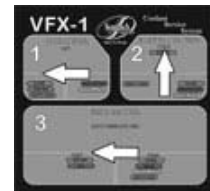

Figure 2

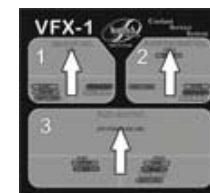

Figure 3

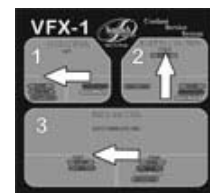

Figure 4

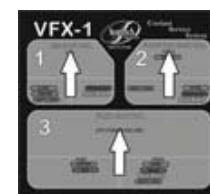

Figure 5

Empty Used Coolant

- 1) Verify all control panel valves are in neutral position, and flow control valves at hose ends are OFF.
- 2) Connect to clean shop air supply (70-120psi).
- 3) Turn AIR CONTROL valve (#1) and FUNCTION CONTROL valve (#2) to the left EMPTY USED (*PURPLE*) and FLUID CONTROL valve (#3) to the right, EMPTY USED (*PURPLE*).
- 4) Connect cone assembly to BLACK/USED coolant flow control valve at hose end. (*Fig 3*)
- 5) Secure cone assembly into used coolant storage vessel. SLOWLY open BLACK/USED coolant flow control valve.

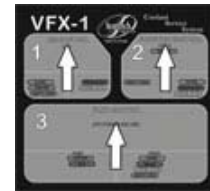

Figure 1

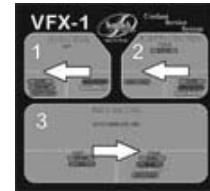

Figure 2



Figure 3

Note: The unit uses regulated air pressure (up to 30psi) to empty the used coolant from the unit. Once the used fluid has been expelled, the air pressure will cause the BLACK/USED coolant hose to “jump” or “jerk. Properly secure the hose to prevent spills.

- 6) Close BLACK/USED coolant flow control valve at hose end when all used coolant drains from unit.
- 7) Return all control panel valves to neutral position. (*Fig 4*)

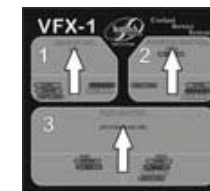

Figure 4

Empty Used Coolant-using HOLD feature

Note: Used coolant tank should not be greater than 50% capacity (7.5 gallons), any percentage of used coolant greater than 50% will not be expelled from tank when using HOLD Feature.

- 1) Verify all control panel valves are in neutral position and flow control valves at hose ends are OFF. (*Fig 1*)
- 2) Connect to clean shop air supply (70-120psi).
- 3) Turn AIR CONTROL valve (#1) and FUNCTION CONTROL valve (#2) to the left and FLUID CONTROL Valve (#3) to the right. (*Fig 2*)
- 4) The pressure inside the used coolant tank will build to 25-30psi as indicated on the unit's compound gauge.
- 5) Turn AIR CONTROL valve (#1) straight up once 25-30psi is achieved on gauge. (*Fig 3*)
- 6) Disconnect shop air supply. EMPTY USED (*PURPLE*) may now be remotely operated.
- 7) Connect cone assembly to BLACK/USED coolant flow control valve at hose end.

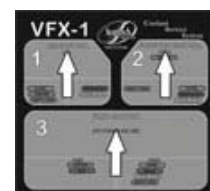

Figure 1

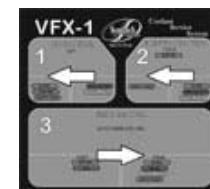

Figure 2

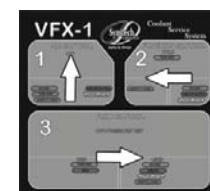

Figure 3

- 8) Secure cone assembly into used coolant storage vessel. SLOWLY open BLACK/USED coolant flow control valve.

Note: The unit uses regulated air pressure (up to 30psi) to empty the used coolant from the unit. Once the used fluid has been expelled, the air pressure will cause the BLACK/USED coolant hose to “jump” or “jerk”. Properly secure the hose to prevent spills.

- 9) Close BLACK/USED coolant flow control valve at hose end when used coolant is drained from unit.
- 10) Return all control panel valves to neutral position. (fig 4)
- 11) If complete evacuation is not achieved, repeat the process.

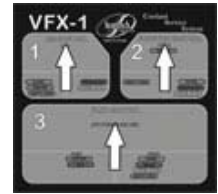

Figure 4

Empty Tool Storage compartment Waste Fluid Reservoir

- 1) Connect clean shop air supply (70-120psi).
- 2) Turn AIR CONTROL valve (#1), FUNCTION CONTROL valve (#2), and FLUID CONTROL Valve (#3) to the right LOWER LEVEL (YELLOW). Vacuum will begin to build on the compound gauge. (Fig 1)
- 3) Connect extraction cone to BLACK/USED coolant flow control valve. (Fig 2)
- 4) Insert extraction cone over tool storage compartment waste fluid reservoir tube and remove all used coolant from reservoir. (Fig 3)
- 5) Open BLACK/USED coolant flow control valve at hose end.
- 6) When used coolant flow ceases, close used coolant flow control valve at hose end.
- 7) Return all control panel valves to correct neutral position, (Fig 4) and flow control valves at hose ends to off.

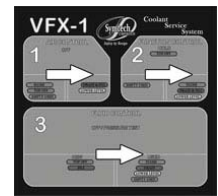

Figure 1



Figure 2



Figure 3

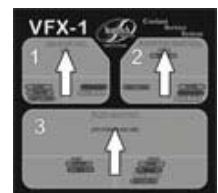

Figure 4

Troubleshooting

PROBLEM	SOLUTION
Vacuum speed or level is reduced	<ul style="list-style-type: none"> - Inadequate air supply. Must maintain 70psi minimum throughout service. - Air powered vacuum venturi has become clogged with debris from dirty air supply. <p>Please contact Symtech for service procedures.</p> <ul style="list-style-type: none"> - Leak in the unit. Please contact Symtech Corporation for service procedures.
Removal of coolant stops prematurely (before all removable coolant is removed)	<ul style="list-style-type: none"> - Cone has become dislodged or unseated from radiator or Remote Reservoir tank neck. Check that cone is properly seated and vacuum level of at least 20inHg can be obtained
Vacuum level of at least 20inHg is obtained but no coolant is removed	<ul style="list-style-type: none"> - Cone may be “bottomed out” on shallow radiator or Remote Reservoir tank neck preventing coolant flow. Cone may need to be trimmed back to prevent “bottoming out”
Used coolant tank sight gauge is too dirty to view level	<ul style="list-style-type: none"> - Sight gauge can be restored to new by emptying used coolant tank and replacing sight gauge with new 17.5” X 3/8 O.D. length of new vinyl tube. Available at Symtech.
Used coolant is leaking from bottom of unit	<ul style="list-style-type: none"> - Used coolant tank has been over-filled and used coolant is escaping through relief valve of tank. - Possible leak inside unit – contact Symtech Corporation for service procedures
New coolant did not or can not adequately refill vehicle	<ul style="list-style-type: none"> - New coolant tank level or supply is empty or coupler disconnected. Check level and replenish if necessary. Check coupler for proper connection to new coolant tank.
Coolant exchange in FLUSH mode does not occur.	<ul style="list-style-type: none"> - Recheck all connections, control panel valve positions, and flow control valve positions and retry. <i>See pages 11 and 12</i> - Reverse RED/NEW and BLACK/USED hose connections and retry. <i>See pages 11 and 12</i> - Start vehicle allowing it to reach normal operating temperature and retry. <i>See pages 11 and 12</i>
All used fluid is not evacuated from used coolant tank when using HOLD feature.	<ul style="list-style-type: none"> - Used coolant in tank is greater than 50% (7.5 gallons). - Attach shop air and repeat all steps of HOLD feature.

WARRANTY STATEMENT

All Symtech Corporation Coolant Service products are warranted to be free from defects in material and workmanship under normal use and service for a period of one year from time of purchase. Adapters and fittings are warranted for a period of ninety (90) days. Exception to this policy will be individually evaluated and must be approved by Symtech Corporate. The sole obligation under this warranty shall be to repair, or replace any defective product, or components thereof which upon examination is/are deemed to the manufacturers satisfaction to be defective.

Warranty shall not apply to any product which has been subject to misuse or negligence. Manufacturer shall not be responsible for any special or consequential damages and the warranty as set forth is in lieu of all other warranties, either expressed or implied. However, the manufacturer makes no warranty of merchantability in respect to any products for any purpose other than that stated in literature and any applicable manufacturers shop or service manuals referred to therein, including subsequent service bulletins.

Proof of purchase MUST accompany all warranty claims.

SERVICE STATEMENT / COMMITMENT

Symtech Corporation prides itself on personal, in-depth, service communication, if you encounter difficulties in the operation, understanding of procedures or have general service questions we urge you to contact us at;

1-888-884-8182

This is not a thoughtless statement as our reputation is directly dependent upon your overall satisfaction.

It is our commitment to you that your satisfaction and favorable equipment experience is foremost to us. We will endeavor to meet the high standard that you expect and deserve.

TECHNICAL SUPPORT

1-888-884-8182

8am to 5pm Central Standard Time.

